

L'unité de guidage en U est un accessoire pour le vérin 15552 VDMA et ISO 6432. Utilisé pour les charges lourdes, les grandes vitesses et le positionnement de précision. Différentes courses sont disponibles pour des diamètres de 16 à 100mm.

CLE DE CODAGE

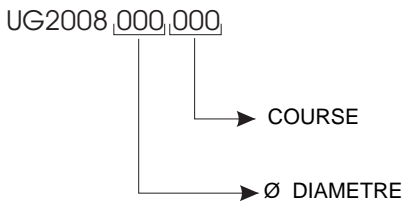

COURSE STANDARD

Ø16	mm 50-100-160-200
Ø20	mm 50-100-160-200
Ø25	mm 50-100-160-200
Ø32	mm 50-100-160-200-250-320-400-500
Ø40	mm 50-100-160-200-250-320-400-500
Ø50	mm 50-100-160-200-250-320-400-500
Ø63	mm 50-100-160-200-250-320-400-500
Ø80	mm 50-100-160-200-250-320-400-500
Ø100	mm 50-100-160-200-250-320-400-500

CHARGE MAXIMUM AUTORISEE

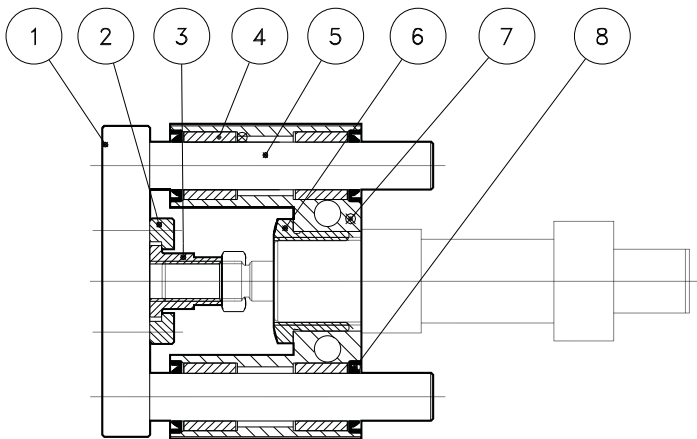
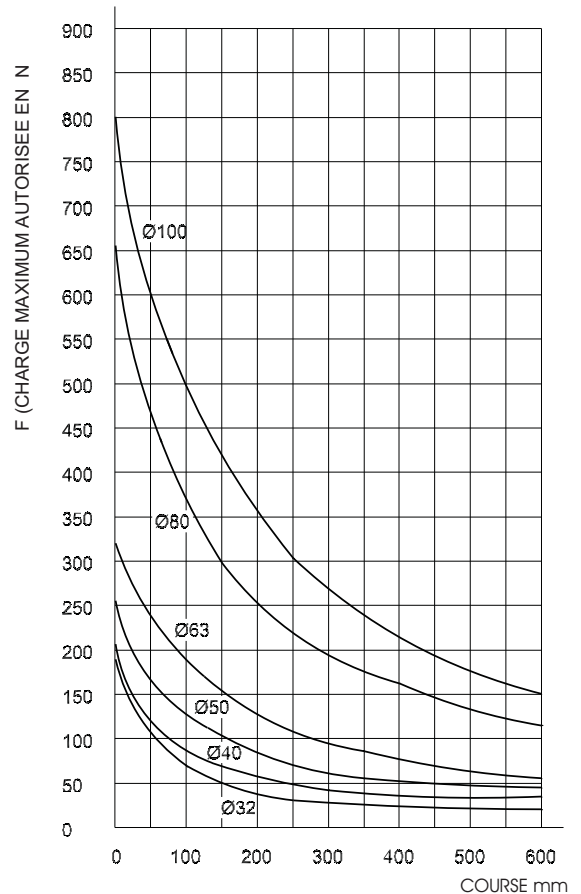
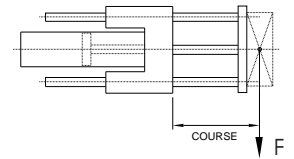

8	GUARNIZIONE TERGIESTA	NBR
7	CORPO PER UNITA' DI GUIDA	Alluminio anodizzato
6	GHIERA FISSAGGIO CILINDRO	Acciaio zincato bianco
5	ASTA DI GUIDA	C40 Cromato
4	BUSSOLA DI GUIDA	Bronzo sinterizzato
3	BUSSOLA DI FISSAGGIO STELO	Acciaio zincato bianco
2	GHIERA DI FISSAGGIO STELO	Acciaio zincato bianco
1	PIASTRA	Alluminio anodizzato
Pos	Denominazione	Materiale

UNITE DE GUIDAGE EN U POUR VERIN ISO 6432

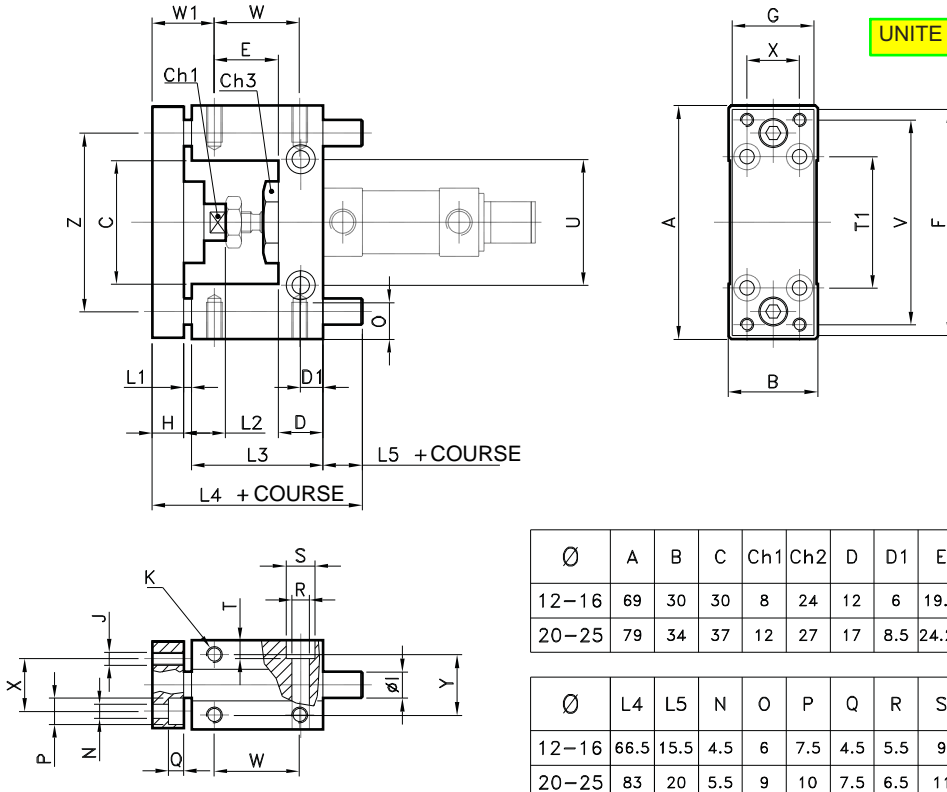

Ø	A	B	C	Ch1	Ch2	D	D1	E	F	G	H	ØI1	J	K	L1	L2	L3
12-16	69	30	30	8	24	12	6	19.5	66	29	10	10	M4	M4	3	15	38
20-25	79	34	37	12	27	17	8.5	24.25	78	32	12	12	M5	M6	3	18	48

Ø	L4	L5	N	O	P	Q	R	S	T	T1	U	V	W	W1	X	Y	Z
12-16	66.5	15.5	4.5	6	7.5	4.5	5.5	9	5.5	32	24	58	25	19.5	18	22	49.5
20-25	83	20	5.5	9	10	7.5	6.5	11	6.5	38	38	68	32.5	21.75	20	23	58

UNITE DE GUIDAGE EN U POUR VERIN ISO 15552

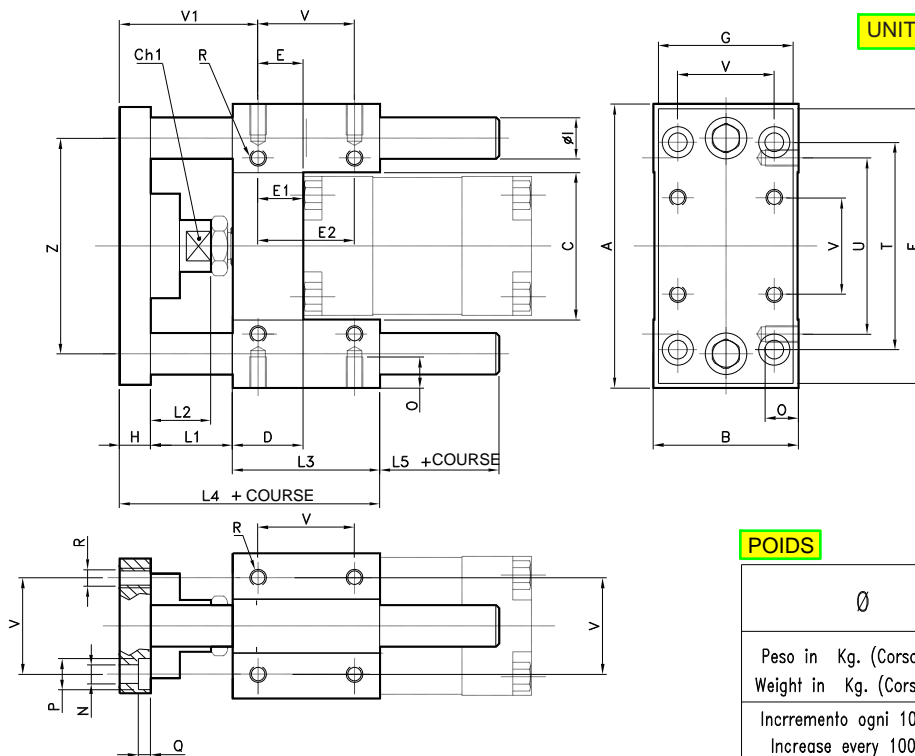

POIDS

Ø	12 16	20 25	32	40	50	63	80	100
Peso in Kg. (Corsa 0) Weight in Kg. (Corsa 0)	0.28	0.48	0.75	1.23	2.15	2.89	5.7	7.95
Incremento ogni 100 mm Increase every 100 mm	0.123	0.178	0.178	0.316	0.5	0.5	0.77	0.77

Ø	A	B	C	Ch	D	E	E1	E2	F	G	H	ØI	L1	L2	L3	L4	L5	N	O	P	Q	R	T	U	V	V1	Z
32	97	49	51	15	17	9.25	9.25	32.5	93	45	12	12	42	25	48	102	18	6.6	12	11	6.5	M6	78	61	32.5	61.75	74
40	115	58	58.2	15	21	11	11	38	112	55	12	16	43	25	58	113	17	6.6	12	11	6.5	M6	84	69	38	65	87
50	137	70	70.2	20	25	18.8	18.8	46.5	134	65	15	20	49	29	59	123	20	9	16	15	8.5	M8	100	85	46.5	70.2	104
63	152	85	85.2	20	25	15.3	15.3	56.5	147	80	15	20	49	29	76	140	21	9	16	15	9	M8	105	100	56.5	73.7	119
80	189	105	105.5	26	34	25	14	50	180	100	20	25	53	27	90	163	30	11	20	18	11	M10	130	130	72	82	148
100	213	130	130.5	26	39	28.5	19	70	206	120	20	25	54	27	110	184	30	11	20	18	11	M10	150	150	89	84.5	173

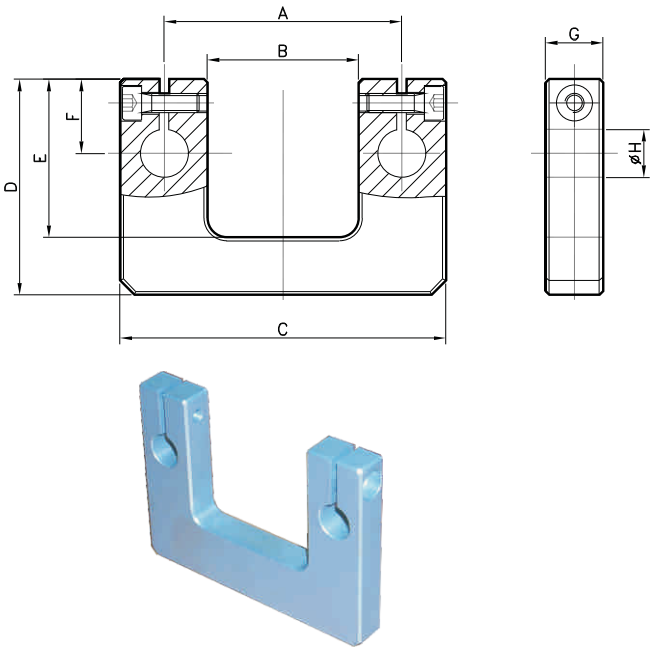

Ø GUIDA	QUOTE								
	A	B	C	D	E	F	G	H1	H2
12-16	49.5	31.5	68	45	33	15.5	12	10	8
20-25	58	37	78	50	34	15.5	12	12	10
32	74	51	95	70	48	23	12	12	12
40	87	58.2	113	80	55	26	12	16	16
50	104	70.2	134	100	67.5	32.5	15	20	20
63	119	91	147	120	82	39.5	15	20	20
80	148	105.5	185	150	101	48.5	20	25	25
100	173	137	209	165	114	49	20	25	25

PLAQUE ARRIERE

COD.	Ø
KG3043016	16
KG3043020	20
KG3043025	25
KG3043032	32
KG3043040	40
KG3043050	50
KG3043063	63
KG3043080	80
KG3043100	100

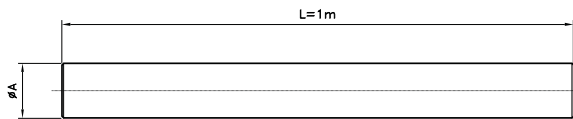

TIGE CHROMEE POUR UNITE DE GUIDAGE AVEC BAGUE EN BRONZE

COD. _____
AC404.O.1000 _____

TIGE NON USINEE

Unità di guida	Ø f7 Bronzine
12	10
16	10
20	12
25	12
32	12
40	16
50	20
63	20
80	25
100	25