

SILENCIEUX

SC

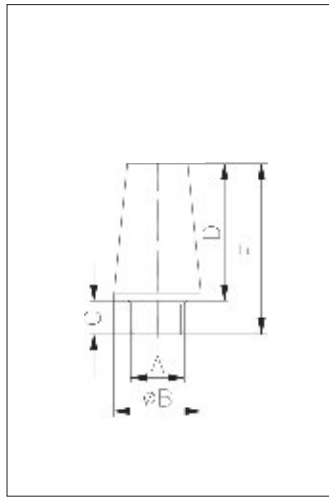

SILENCIEUX BRONZE FRITTE

CODE	A	ØB	C	D	E	
SC 1/8	G1/8	11,5	4,5	16,5	21,0	50
SC 1/4	G1/4	15,0	6,0	19,0	25,0	50
SC 3/8	G3/8	19,0	7,0	27,5	34,5	50
SC 1/2	G1/2	23,0	8,0	35,0	43,0	25
SC 3/4	G3/4	30,0	9,0	41,0	50,0	20
SC 1	G1	37,0	11,0	49,5	60,5	10

SET

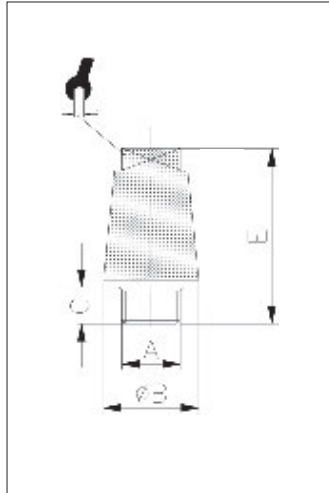

SILENCIEUX BRONZE FRITTE AVEC CARRE DE SERRAGE

CODE	A	ØB	C	E		
SET 1/8	G1/8	11,5	4,5	21,5	8	50
SET 1/4	G1/4	15,0	6,0	28,0	10	50
SET 3/8	G3/8	19,0	7,0	36,0	13	50
SET 1/2	G1/2	23,0	8,0	43,0	15	25
SET 3/4	G3/4	30,0	9,0	56,0	19	20
SET 1	G1	37,0	11,0	69,0	24	10
SET M5	M5	8,5	5,0	19,5	-	50

SEB

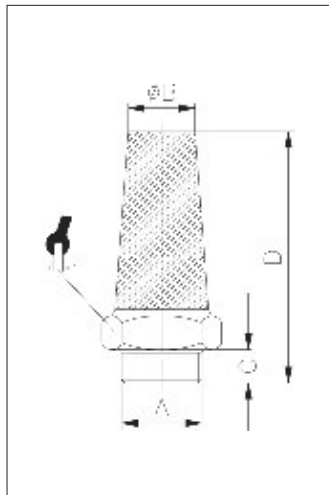

SILENCIEUX EMBASE EN LAITON CORPS BRONZE FRITTE

CODE	A	ØB	C	D		
SEB 1/8	G1/8	8,5	4,5	21,0	12	50
SEB 1/4	G1/4	11,0	6,0	27,0	15	50
SEB 3/8	G3/8	14,0	7,0	35,0	19	50
SEB 1/2	G1/2	17,0	8,0	40,5	23	25
SEB 3/4	G3/4	21,0	9,0	51,5	30	20
SEB 1	G1	26,5	11,0	66,0	36	10
SEB M5	M5	4,5	3,5	17,0	7	50

SPD

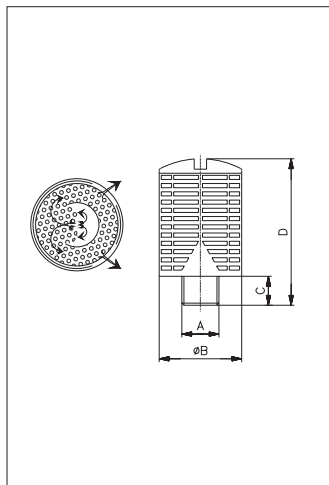

SILENCIEUX EN PLASTIQUE AUTONETTOYANT

CODE	A	ØB	C	D	
SPD 1/8	G1/8	15,0	6,0	32,5	50
SPD 1/4	G1/4	19,5	8,0	43,0	50
SPD 3/8	G3/8	24,5	11,0	58,0	50
SPD 1/2	G1/2	24,5	11,0	58,0	25
SPD 3/4	G3/4	48,0	18,0	115,0	20
SPD 1	G1	48,0	18,0	115,0	10

SRE

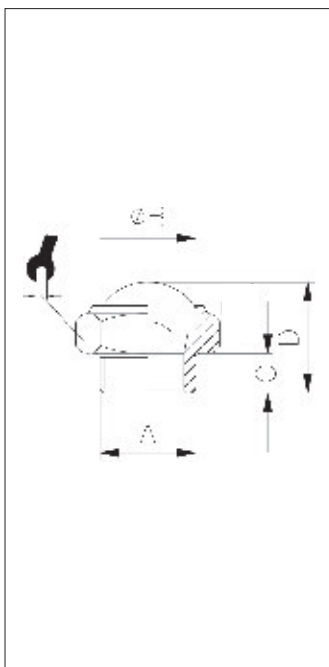

SILENCIEUX EMBASE EN LAITON FIL EN ACIER INOXYDABLE

CODE	A	ØB	C	D		
SRE 1/8	G1/8	11	6,0	15,0	13	50
SRE 1/4	G1/4	14	7,0	18,0	16	50
SRE 3/8	G3/8	17	8,0	20,0	19	50
SRE 1/2	G1/2	22	10,0	22,0	24	25
SRE 3/4	G3/4	28	10,0	26,0	30	20
SRE 1	G1	34	12,0	28,0	36	10
SRE M5	M5	6,5	4,0	8,0	8	50

SPE

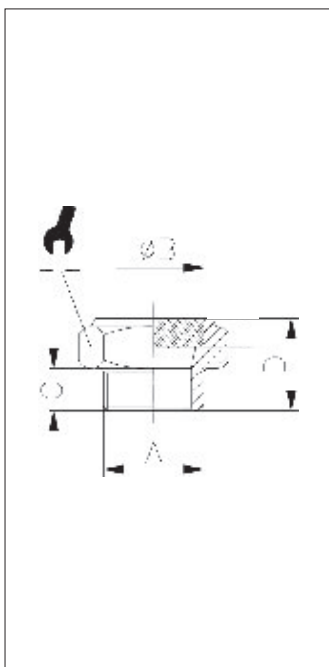

SILENCIEUX EMBASE EN LAITON PASTILLE EN BRONZE FRITTE

CODE	A	ØB	C	D		
SPE 1/8	G1/8	11,0	6,0	13,0	13	50
SPE 1/4	G1/4	14,0	8,0	16,0	16	50
SPE 3/8	G3/8	17,0	9,0	18,0	19	50
SPE 1/2	G1/2	22,0	11,0	18,0	24	25
SPE 3/4	G3/4	28,0	13,0	22,0	30	20
SPE 1	G1	34,0	15,0	23,0	36	10
SPE M5	M5	6,5	3,5	8,0	8	50

SBR

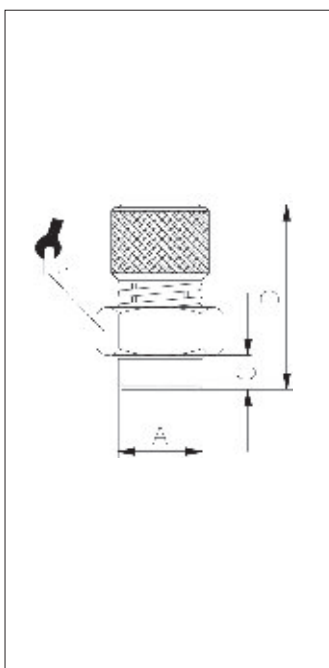

SILENCIEUX AVEC REGULATEUR D'ECHAPPEMENT

CODE	A	C	Dmin.	Dmax.		
SBR 1/8	G1/8	6,0	26,0	28,0	13	50
SBR 1/4	G1/4	8,0	30,0	32,0	15	50
SBR 3/8	G3/8	10,0	35,0	38,0	22	25
SBR 1/2	G1/2	10,0	36,0	39,0	22	25



TRANSMATIK

TRANSMATIK

4RUE DES ESSIOS
51430 BEZANNES

TEL :03.26.86.45.42
FAX : 03.26.86.49.11
www.transmatik.fr

Informations : ma.bur@transmatik.fr

ACCESSOIRES PNEUMATIQUES